

Quick Start Guide

Check Package Contents

Prüfen des Packungsinhalts | Comprobación del contenido del paquete
 Vérification du contenu de l'emballage | Controllo del contenuto della confezione
 Проверка комплектации устройства | Kontrollera förpackningens innehåll
 检查包装内容 | 检查包装内容

- Switch
- Power adaptor/Power cord | Netzadapter/Netzkaabel | Adaptador de alimentación/Cable de alimentación | Adaptateur d'alimentation/Cordon d'alimentation | Alimentatore/Cavo di alimentazione | Адаптер питания/Кабель питания | Nätkabeln/Strömadaptern | 电源适配器/电源线 | 電源變壓器/電源線
- Quick Start Guide | Kurzanleitung in Druckform | Guía de inicio rápido impresa | Guide d'installation rapide imprimé | Breve guida all'installazione | Краткое руководство | Snabbstartguide | 快速入门指南印刷本 | 快速入門指南印刷本
- Warranty card | Garantiekarte | Tarjeta de garantía | Carte de garantie | Scheda di garanzia | Гарантийный талон | Garantkort | 保修卡 | 保固卡
- Mounting Kit | Montagezubehör | Kit de montage | Kit de fixation | Kit di montaggio | Монтажный комплект | Monteringsatts | 安装套件 | 安裝套件

Connecting the Hardware

Anschließen der Hardware | Conectar el hardware
 Connecter le matériel | Collegamento dell'hardware
 Подключение | Ansluta maskinvara
 连接硬件 | 連接硬體

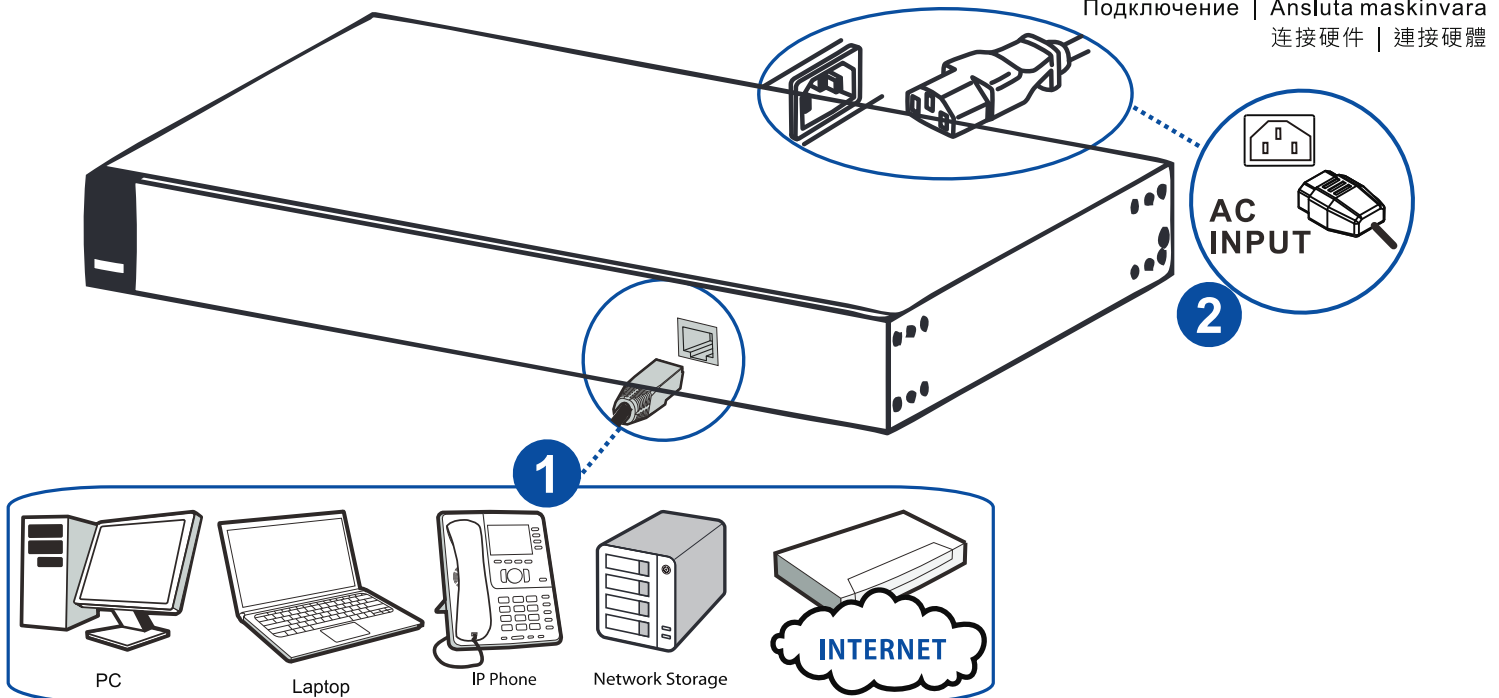

Rack Mounting

Rack-Montage | Instalación en Rack
 Installation en Châssis | Installazione in armadio Rack
 Установка в стойку | Hyllmontering
 支架安裝 | 安裝於標準機架上

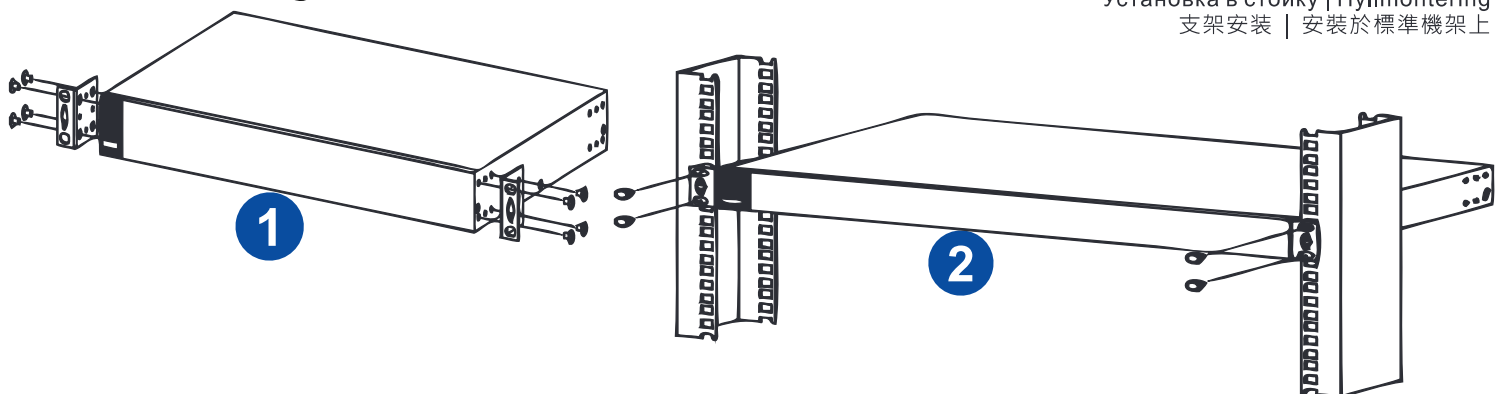

Wall Mounting

Wandmontage | Montaje en pared
 Fixation murale | Montaggio a muro
 Настенный монтаж | Väggmontage
 挂壁式安裝 | 壁掛式安裝

